



ERNI MicroStac

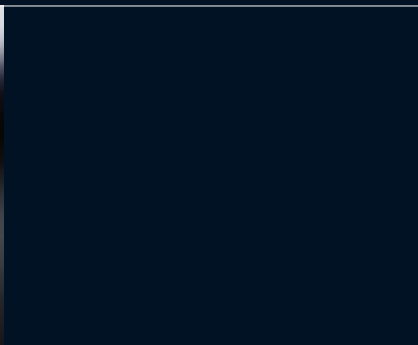



Table of Contents

Applications	4
Technical Features	4
Electrical And Mechanical Characteristics	6
6 Pin Single Row Version	8
12 Pin Single Row Version	10
50 Pin Dual Row Version	12
Packaging	14
Mating Conditions for MicroStac	15
More SMT Connectors from ERNI	16
Part Number Index	18

Applications



- Sensor engineering: Light barriers, switches
- Medical engineering: Intensive medical equipment, portable diagnostics
- Mobile communication: Mobile phones, PDAs, organizer, memory modules
- Car electronics: Car radios, mobile car phones, mobile car office equipment
- Control engineering: Mini PLCs, fieldbus modules, mini solenoid systems
- Facility management: Signal and indicator devices, alarm systems and bus modules

Technical Features

Derating Curve

In spite of the small design of the ERNI MicroStac series, they reach a high current rating. The contacts feature large radiant surfaces to derive heat. The derating curve shows the 50pin version without PCB.

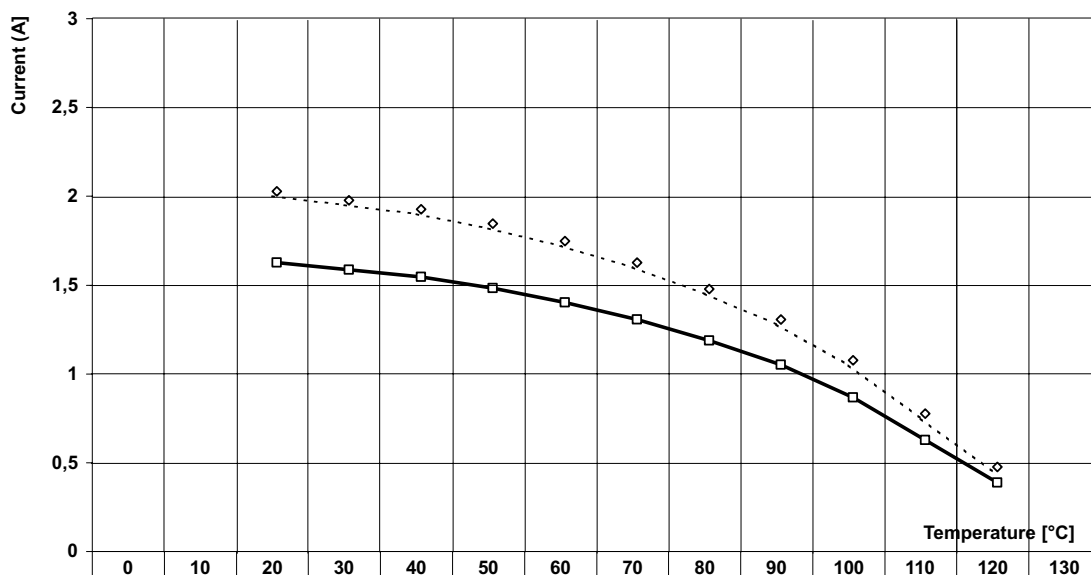

Base curve [A]			2	1,95	1,9	1,82	1,72	1,6	1,45	1,28	1,05	0,75	0,45	
Derating curve [A]			1,6	1,56	1,52	1,456	1,376	1,28	1,16	1,024	0,84	0,6	0,36	

Technical Features



Controlled SMT Reflow Soldering Process

The heat-resistant thermoplastic insulator and precision coplanar contacts permit a controlled SMT soldering process.



Easy Recognition and Safe Handling

The black insulator ensures easy visual recognition by the automatic pick-and-place equipment.



Safe Packaging and Fully Automated Feed

The antistatic tape-and-reel packaging not only protects the high-precision contacts and coplanarity of our MicroStac connectors, but also permits placement of connectors by automated pick and place equipment.

Electrical And Mechanical Characteristics

	Standard	1 Row and 2 Row Types
Number of Pins		6, 12 and 50
Technical data		
Climate Category	DIN EN 60068-1 test b	-55/125/21
Bearing and operating temperature area		-55/125 °C
Current rating	IEC60512 test 5b	By ambient temperature: 20°C 1,6 A 70°C 1,3 A 100°C 0,8 A
Air – and creepage distance		0,4mm
Comparative figure of voltage	IEC 60112	CTI-250
Voltage rating	IEC 60664	Has to be determined according to client-specific using case (degree of environmental pollution) according to IEC 60664
Dielectric strength	IEC 60512	contact – contact 500V
Contact resistance	IEC 60512 test 2a	< 10 mΩ
Insulation resistance	IEC 60512 test 3a	> 10 ⁴ MΩ
Vibration	IEC 60512 test 6d	10 – 2000 Hz 20g
Contact disturbance (while vibration sine)	IEC 60512 test 2e	< 1 μs
Shock halfsine	IEC 60512 test 6c	50g 11 ms
Contact disturbance (while shock halfsine)	IEC 60512 test 2e	< 1 μs
Mechanical operation (mating cycles)	IEC 60512 test 9a	> 10 mating cycles
Insertion and withdrawal force	IEC 60512 test 13b	6 cont.: 12 N max. 12 cont.: 24 N max. 50 cont.: 100 N max.

Electrical And Mechanical Characteristics

	Standard	1 Row and 2 Row Types
Number of Pins		6, 12 and 50
Process-conditions		
Hand soldering temperature max.	IEC 68-2-20	3,5s at 350°C
SMT-Reflow soldering temperature max.	IEC 68-2-20	10s at 260°C
Coplanarity		< 0,1mm
Materials		
Housing: plastic material (symbol)		PA 46
CTI value	IEC 60112	CTI 250
UL flame rating		UL 94 V-0
UL file		E 119177
Contact and mating area		
Base material		Cu alloy
Plating		Au over Ni
Termination area		
Base material		Cu alloy
Plating		Au
Environment compatibility		
recycling	no flame-retardent additives, no toxic additives allow easy recycling	

6 Pin Single Row Version



The SMT connector series MicroStac with 0.8 mm pitch and with SMT termination is based on a hermaphroditic design. As result of this the male and the female connector are identical. The same style for male and female connector meet the requirement for a economical connector solution in modern applications in electronics. The dual-sided PCB application contact principle provides for a tilt-proof and insertion-proof connector position on the PCB. The gripper surface is integrated within the insulator body. This obviates the need for the standard assembly hood. Optionally, versions featuring positioning pegs are also available. Using the MicroStac a board-to-board height from 5.0 mm up to 6.5 mm is achieved.

Dimensional Drawing

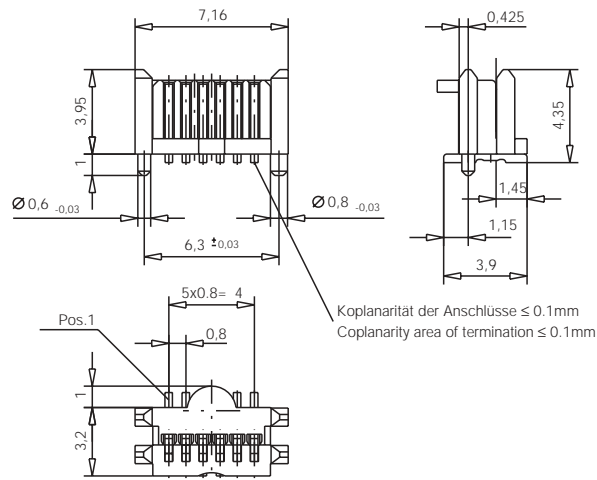

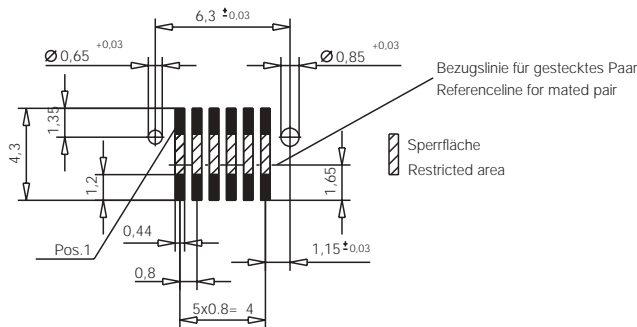

Leiterplatten-Layout Vorschlag
PCB-Layout Proposal



All dimensions in mm

6 Pin Single Row Version

Ordering Information

Configuration	Height	No. of Pins	Part Number
Single row with peg, tape and reel, 1500 pcs/reel 		6	114711
Single row without peg, tape and reel, 1500 pcs/reel 		6	114881

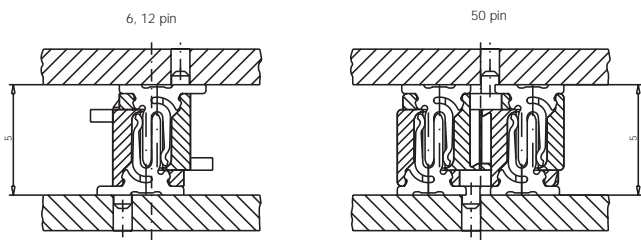

All dimensions in mm

www.ERNI.com/contact/

12 Pin Single Row Version



The SMT connector series MicroStac with 0.8 mm pitch and with SMT termination is based on a hermaphroditic design. As result of this the male and the female connector are identical. The same style for male and female connector meet the requirement for a economical connector solution in modern applications in electronics. The dual-sided PCB application contact principle provides for a tilt-proof and insertion-proof connector position on the PCB. The gripper surface is integrated within the insulator body. This obviates the need for the standard assembly hood. Optionally, versions featuring positioning pegs are also available. Using the MicroStac a board-to-board height from 5.0 mm up to 6.5 mm is achieved.

Dimensional Drawing

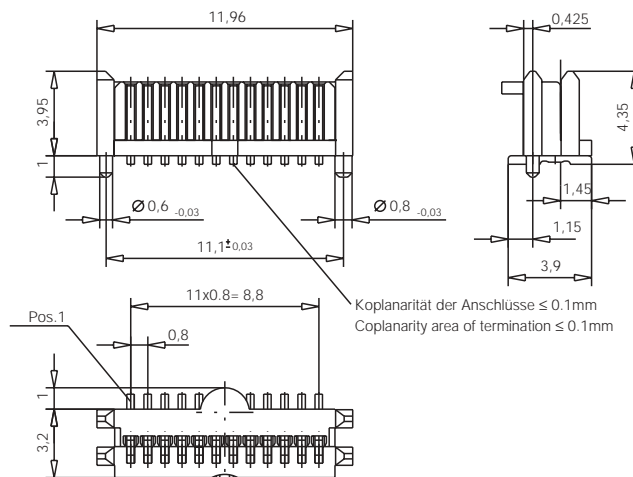

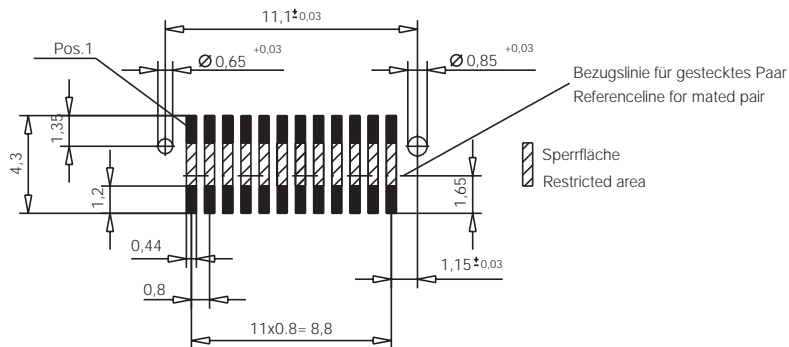

Leiterplatten-Layout Vorschlag
PCB-Layout Proposal



All dimensions in mm

12 Pin Single Row Version

Ordering Information

Configuration	Height	No. of Pins	Part Number
Single row with peg, tape and reel, 1500 pcs/reel 		12	114712
Single row without peg, tape and reel, 1500 pcs/reel 		12	114882

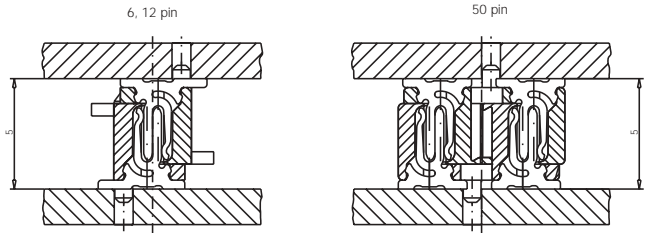

All dimensions in mm

50 Pin Dual Row Version

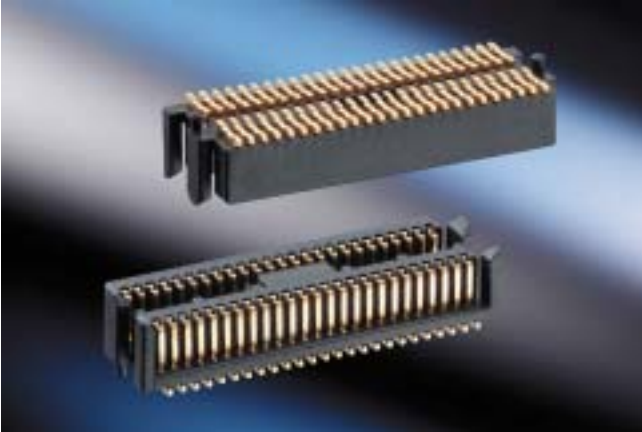

The SMT connector series MicroStac with 0.8 mm pitch and with SMT termination is based on a hermaphroditic design. As result of this the male and the female connector are identical. The same style for male and female connector meet the requirement for a economical connector solution in modern applications in electronics. The dual-sided PCB application contact principle provides for a tilt-proof and insertion-proof connector position on the PCB. The gripper surface is integrated within the insulator body. This obviates the need for the standard assembly hood. Optionally, versions featuring positioning pegs are also available. Using the MicroStac a board-to-board height from 5.0 mm up to 6.5 mm is achieved.

Dimensional Drawing

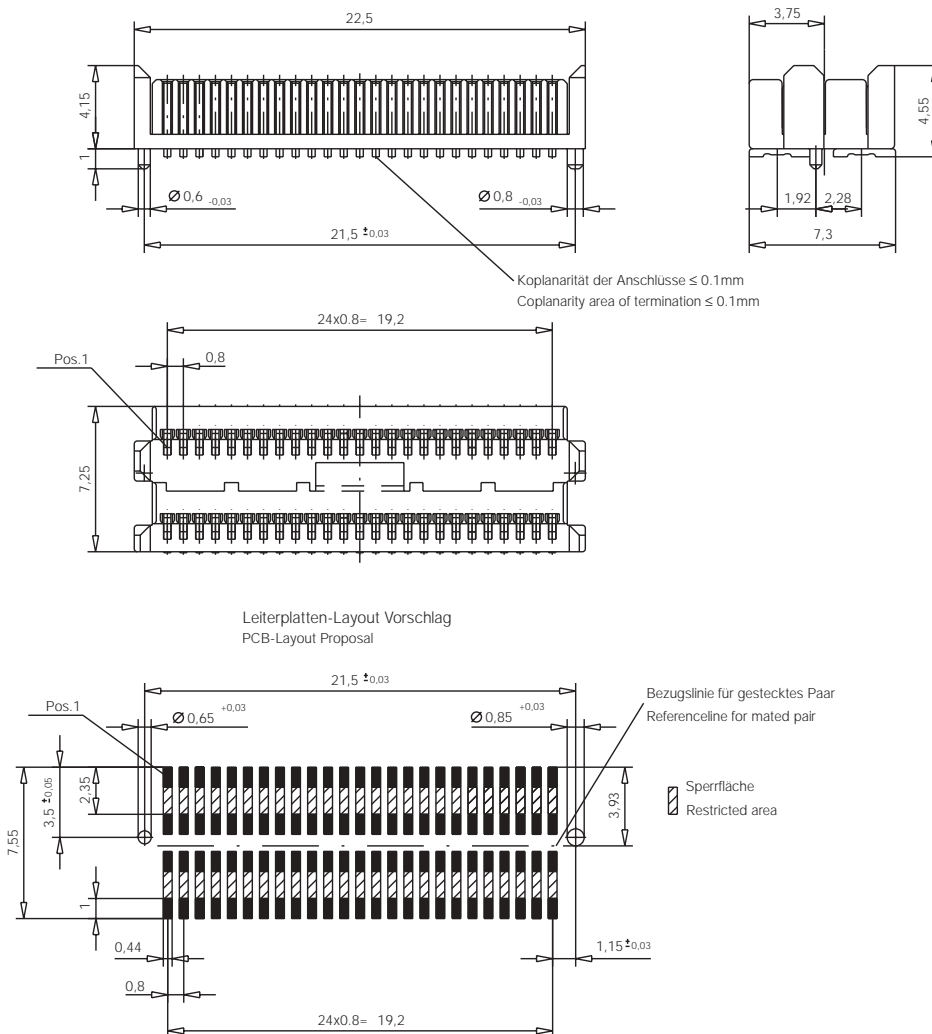

All dimensions in mm

50 Pin Dual Row Version

Ordering Information

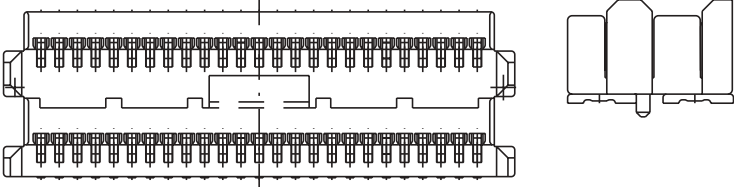
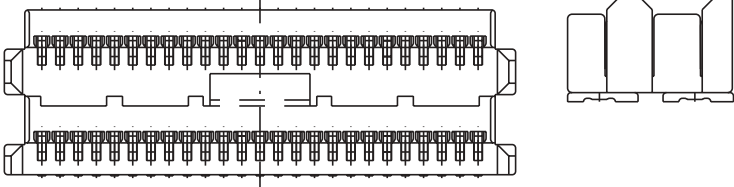
Configuration	Height	No. of Pins	Part Number
Dual row with peg, tape and reel, 1000 pcs/reel 		50	114713
Dual row without peg, tape and reel, 1000 pcs/reel 		50	114883

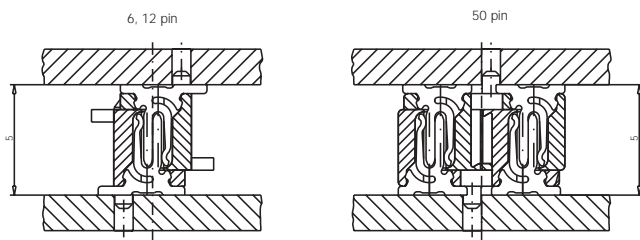

All dimensions in mm

www.ERNI.com/contact/

Packaging

6 Pin Version

Tape and Reel Packaging - Packaging unit: 1500 pcs

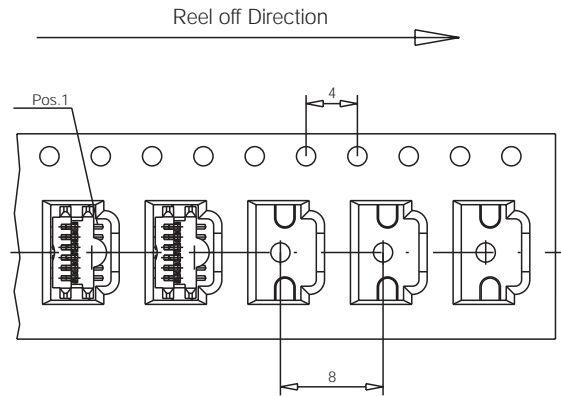
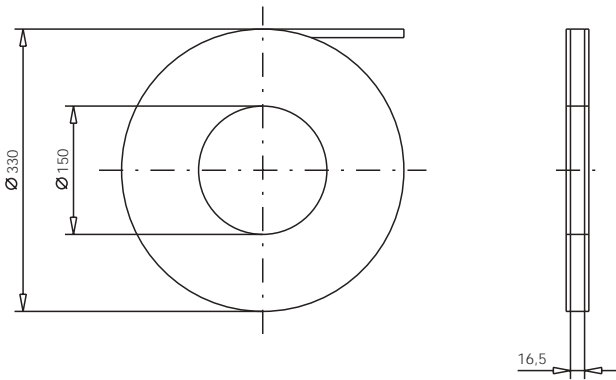

12 Pin Version

Tape and Reel Packaging - Packaging unit: 1500 pcs

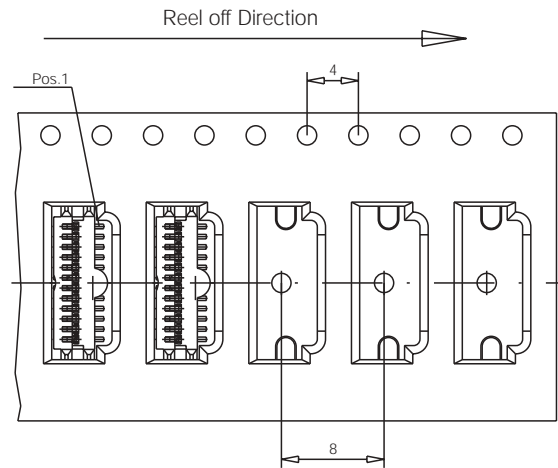
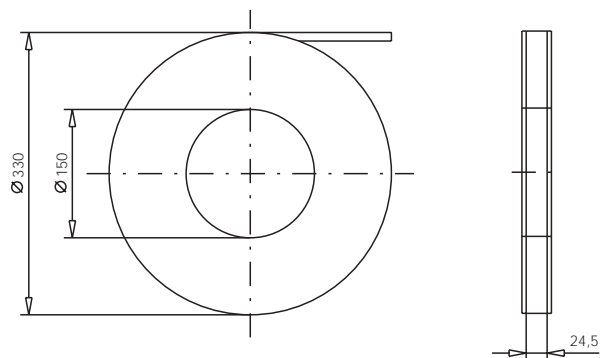

50 Pin Version

Tape and Reel Packaging - Packaging unit: 1000 pcs

All dimensions in mm

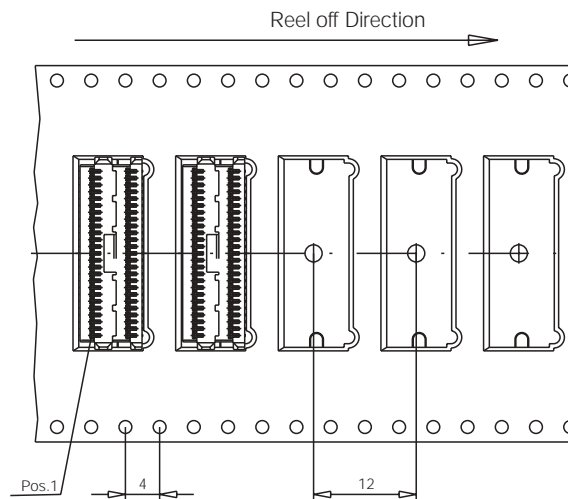
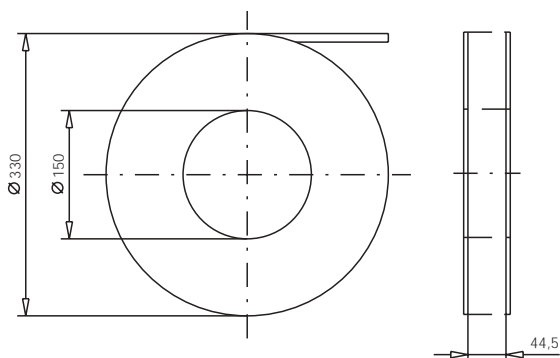

Mating Conditions for MicroStac

Misalignment Tolerances longitudinal: $\pm 0.7\text{mm}$; transverse: $\pm 0.5\text{mm}$

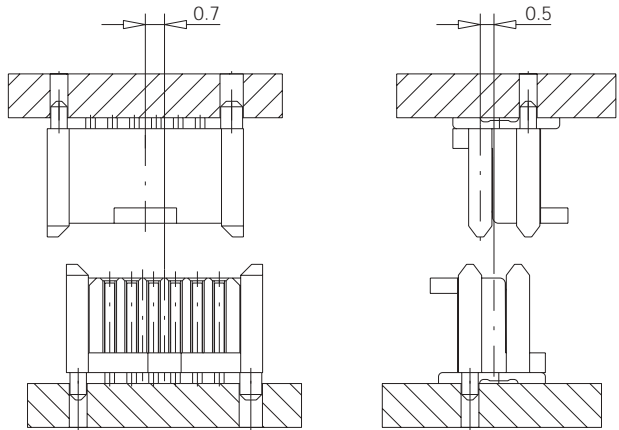

Angular Inclination Tolerances longitudinal: $\pm 4^\circ$; transverse: $\pm 4^\circ$

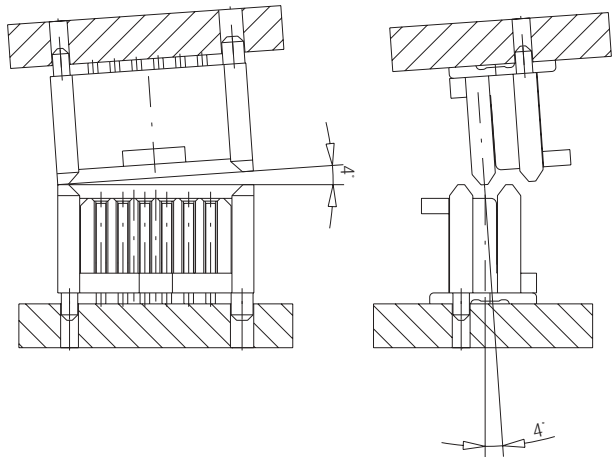

"Board to Board" Height distance: 5.0-6.5 mm

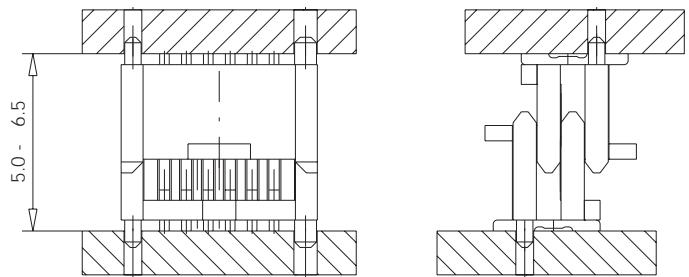

All dimensions in mm

More SMT Connectors from ERNI

Right Angle Surface Mount D-Sub Connector

Modern Sub Rack Technology is increasing the demand for SMT components along with the requirement for the connectors supporting this technology. ERNI is meeting the need by developing a new generation of the classic I/O D-Sub connector which uses surface mount technology.



High Speed Differential Connector System ERmet zeroXT for 10 GBit/s

For modern high speed backplane designs with data transmission rates up to 10 Gbit/s ERNI has developed the new ERmet zeroXT Connector System with 100 Ohm matched differential impedance for enhanced signal integrity. The new connector system is specifically designed to meet the challenging electrical performance needs required by next generation designs utilizing low voltage differential signaling. The ERmet zeroXT now offers an innovative shielding design and SMT termination to provide very low cross-talk, low skew and improved trace routing. Additional features and benefits are a reliable female contact design, different mating levels and a rugged housing.

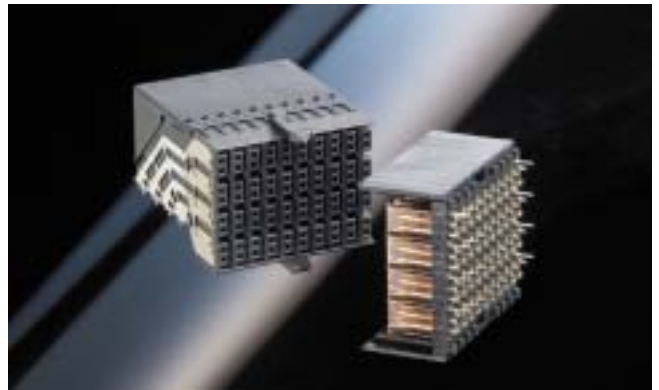

SMC 1.27 mm pitch

SMC connectors are excellently suited for efficient processing in modern SMT soldering systems. Easy population, optimum seating and attachment by integrated retaining clips, and the exact position of the connection pins make SMC connectors into a real SMT component. We supply SMC connectors on a reel for the automatic assembly.



Single Port Mod Jacks

- Various pin configurations e.g. RJ 11, RJ 45
- Shielded or unshielded
- Standard or ultra low profile
- Right angle Versions
- SMT termination
- LED versions







Part Number Index

Part Number	Page
114881	9
114711	9
114882	11
114712	11
114883	13
114713	13



Member



VMEbus INTERNATIONAL TRADE ASSOCIATION



ERNI Elektroapparate GmbH

Seestrasse 9, Postfach
73099 Adelberg, Deutschland
Tel +49 (0)71 66 50-0
Fax +49 (0)71 66 50-282
info@erni.de

Europe South America Africa

ERNI Components, Inc.

12701 Kingston Avenue
Chester, VA 23836 USA
Tel +1 (804) 530-5012
Fax +1 (804) 530-5232
info@ernicomponents.com

North America Canada Mexico

ERNI Asia Holding Pte Ltd.

Blk 4008 Ang Mo Kio Avenue 10
#04-01/02 Techplace I
Singapore 569625
Tel +65 6 555 5885
Fax +65 6 555 5995
info@erni-asia.com

Asia

www.erni.com

ERNI Elektroapparate GmbH 2001 • Printed in Germany.

A policy of continuous improvement is followed and the right to alter any published data without notice is reserved.